

# SIEMENS

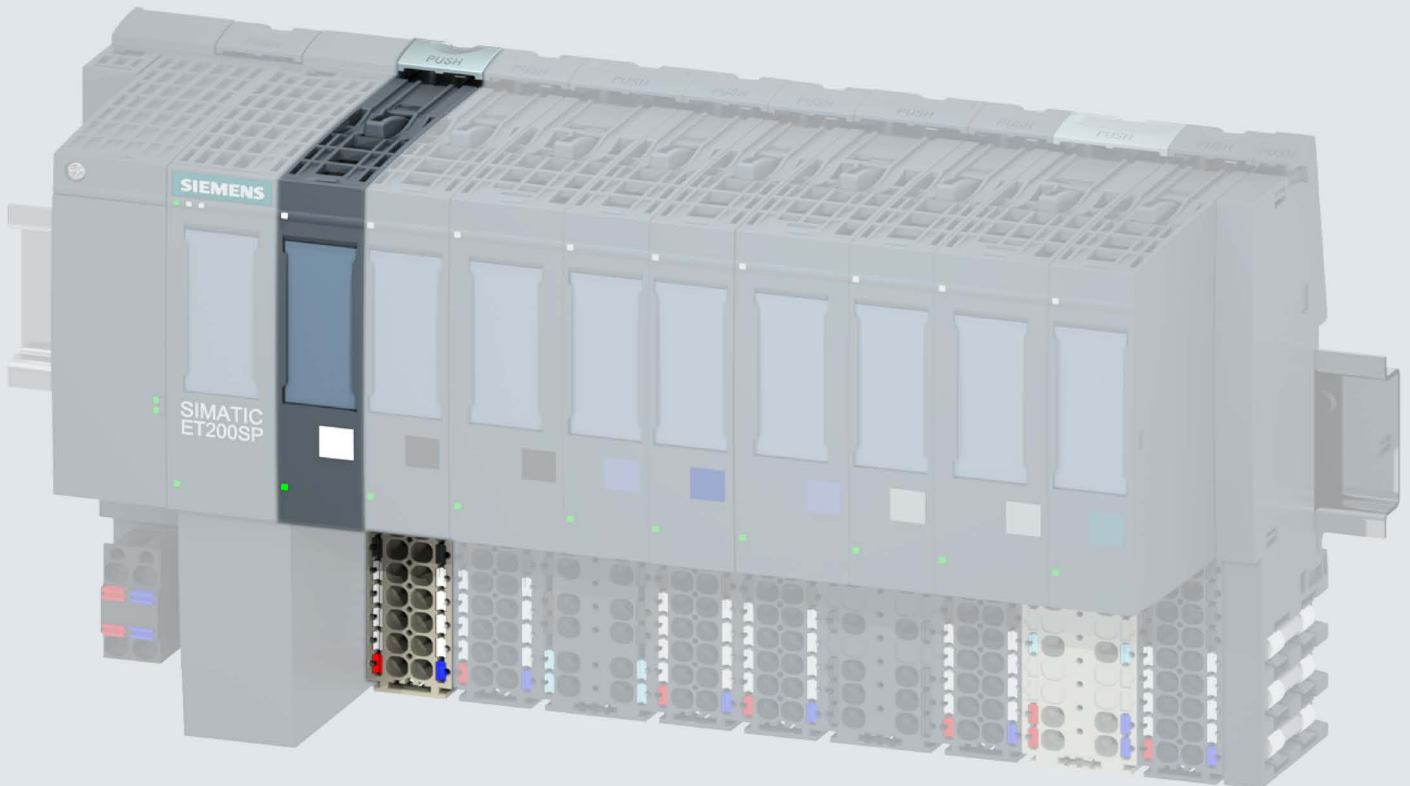

Manual

# SIMATIC

## ET 200SP

Digital input module  
DI 8x24VDC SRC BA (6ES7131-6BF61-0AA0)

Edition

02/2019

[support.industry.siemens.com](http://support.industry.siemens.com)

# SIEMENS

## SIMATIC

### ET 200SP

Digital output module  
DI 8x24VDC SRC BA  
(6ES7131-6BF61-0AA0)

Manual

Preface

---

Documentation guide

1

Product overview

2

Wiring

3

Parameters/address space

4

Interrupts/diagnostics alarms

5

Technical specifications

6

Parameter data record

A

## Legal information

### Warning notice system

This manual contains notices you have to observe in order to ensure your personal safety, as well as to prevent damage to property. The notices referring to your personal safety are highlighted in the manual by a safety alert symbol, notices referring only to property damage have no safety alert symbol. These notices shown below are graded according to the degree of danger.

<b>⚠ DANGER</b>
indicates that death or severe personal injury <b>will</b> result if proper precautions are not taken.
<b>⚠ WARNING</b>
indicates that death or severe personal injury <b>may</b> result if proper precautions are not taken.
<b>⚠ CAUTION</b>
indicates that minor personal injury can result if proper precautions are not taken.
<b>NOTICE</b>
indicates that property damage can result if proper precautions are not taken.

If more than one degree of danger is present, the warning notice representing the highest degree of danger will be used. A notice warning of injury to persons with a safety alert symbol may also include a warning relating to property damage.

### Qualified Personnel

The product/system described in this documentation may be operated only by **personnel qualified** for the specific task in accordance with the relevant documentation, in particular its warning notices and safety instructions. Qualified personnel are those who, based on their training and experience, are capable of identifying risks and avoiding potential hazards when working with these products/systems.

### Proper use of Siemens products

Note the following:

<b>⚠ WARNING</b>
Siemens products may only be used for the applications described in the catalog and in the relevant technical documentation. If products and components from other manufacturers are used, these must be recommended or approved by Siemens. Proper transport, storage, installation, assembly, commissioning, operation and maintenance are required to ensure that the products operate safely and without any problems. The permissible ambient conditions must be complied with. The information in the relevant documentation must be observed.

### Trademarks

All names identified by ® are registered trademarks of Siemens AG. The remaining trademarks in this publication may be trademarks whose use by third parties for their own purposes could violate the rights of the owner.

### Disclaimer of Liability

We have reviewed the contents of this publication to ensure consistency with the hardware and software described. Since variance cannot be precluded entirely, we cannot guarantee full consistency. However, the information in this publication is reviewed regularly and any necessary corrections are included in subsequent editions.

# Preface

## Purpose of the documentation

This manual supplements the system manual ET 200SP distributed I/O system (<http://support.automation.siemens.com/WW/view/en/58649293>).

Functions that generally relate to the system are described in this manual.

The information provided in this manual and in the system/function manuals supports you in commissioning the system.

## Changes compared to previous version

Compared to the previous version, this manual contains the following change:

Technical specifications: Ambient temperature in horizontal and vertical mounting position, extended to min. -30 °C.

## Conventions

CPU: When the term "CPU" is used in this manual, it applies to the CPUs of the S7-1500 automation system as well as to the CPUs/interface modules of the distributed I/O system ET 200SP.

STEP 7: In this documentation, "STEP 7" is used as a synonym for all versions of the configuration and programming software "STEP 7 (TIA Portal)".

Please also observe notes marked as follows:

---

### Note

A note contains important information on the product described in the documentation, on the handling of the product or on the section of the documentation to which particular attention should be paid.

---

## Security information

Siemens provides products and solutions with industrial security functions that support the secure operation of plants, systems, machines and networks.

In order to protect plants, systems, machines and networks against cyber threats, it is necessary to implement – and continuously maintain – a holistic, state-of-the-art industrial security concept. Siemens' products and solutions constitute one element of such a concept.

Customers are responsible for preventing unauthorized access to their plants, systems, machines and networks. Such systems, machines and components should only be connected to an enterprise network or the internet if and to the extent such a connection is necessary and only when appropriate security measures (e.g. firewalls and/or network segmentation) are in place.

For additional information on industrial security measures that can be implemented, please visit (<http://www.siemens.com/industrialsecurity>).

Siemens' products and solutions undergo continuous development to make them more secure. Siemens strongly recommends that product updates are applied as soon as they are available and that the latest product versions are used. Use of product versions that are no longer supported, and failure to apply the latest updates may increase customers' exposure to cyber threats.

To stay informed about product updates, subscribe to the Siemens Industrial Security RSS Feed visit (<http://www.siemens.com/industrialsecurity>).

# Table of contents

	<b>Preface .....</b>	<b>3</b>
<b>1</b>	<b>Documentation guide .....</b>	<b>6</b>
<b>2</b>	<b>Product overview .....</b>	<b>10</b>
	2.1 Properties.....	10
<b>3</b>	<b>Wiring .....</b>	<b>12</b>
	3.1 Wiring and block diagram .....	12
<b>4</b>	<b>Parameters/address space .....</b>	<b>15</b>
	4.1 Parameters .....	15
	4.2 Explanation of parameters .....	17
	4.3 Address space .....	18
<b>5</b>	<b>Interrupts/diagnostics alarms.....</b>	<b>19</b>
	5.1 Status and error displays .....	19
	5.2 Interrupts.....	21
	5.3 Diagnostics alarms.....	21
<b>6</b>	<b>Technical specifications .....</b>	<b>22</b>
	6.1 Technical specifications .....	22
<b>A</b>	<b>Parameter data record .....</b>	<b>26</b>
	A.1 Parameter assignment and structure of parameter data record.....	26

# Documentation guide

The documentation for the SIMATIC ET 200SP distributed I/O system is arranged into three areas.

This arrangement enables you to access the specific content you require.

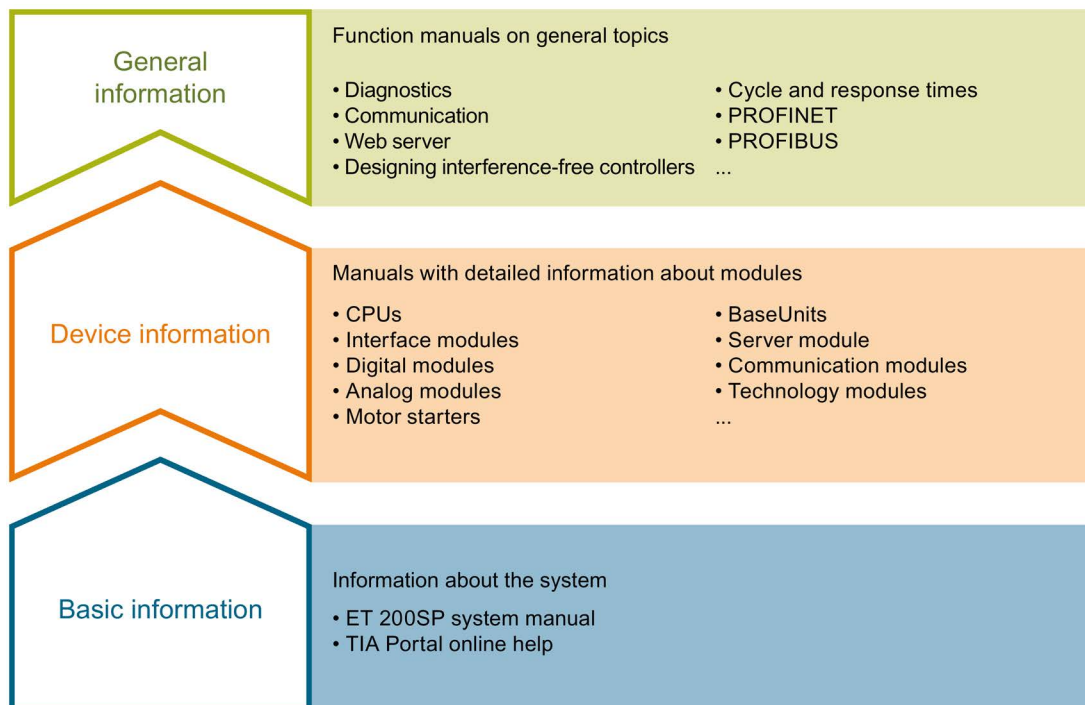

## Basic information

The system manual describes in detail the configuration, installation, wiring and commissioning of the SIMATIC ET 200SP. distributed I/O system. The STEP 7 online help supports you in the configuration and programming.

## Device information

Product manuals contain a compact description of the module-specific information, such as properties, wiring diagrams, characteristics and technical specifications.

## General information

The function manuals contain detailed descriptions on general topics regarding the SIMATIC ET 200SP distributed I/O system, e.g. diagnostics, communication, Web server, motion control and OPC UA.

You can download the documentation free of charge from the Internet (<https://support.industry.siemens.com/cs/ww/en/view/109742709>).

Changes and supplements to the manuals are documented in a Product Information.

You can download the product information free of charge from the Internet (<https://support.industry.siemens.com/cs/us/en/view/73021864>).

## Manual Collection ET 200SP

The Manual Collection contains the complete documentation on the SIMATIC ET 200SP distributed I/O system gathered together in one file.

You can find the Manual Collection on the Internet (<https://support.automation.siemens.com/WW/view/en/84133942>).

## "mySupport"

With "mySupport", your personal workspace, you make the most of your Industry Online Support.

In "mySupport" you can store filters, favorites and tags, request CAx data and put together your personal library in the Documentation area. Furthermore, your data is automatically filled into support requests and you always have an overview of your current requests.

You need to register once to use the full functionality of "mySupport".

You can find "mySupport" in the Internet (<https://support.industry.siemens.com/My/ww/en>).

## "mySupport" - Documentation

In the Documentation area of "mySupport", you have the possibility to combine complete manuals or parts of them to make your own manual.

You can export the manual in PDF format or in an editable format.

You can find "mySupport" - Documentation in the Internet (<https://support.industry.siemens.com/My/ww/en/documentation>).

## "mySupport" - CAx Data

In the CAx Data area of "mySupport", you can have access the latest product data for your CAx or CAe system.

You configure your own download package with a few clicks.

In doing so you can select:

- Product images, 2D dimension drawings, 3D models, internal circuit diagrams, EPLAN macro files
- Manuals, characteristics, operating manuals, certificates
- Product master data

You can find "mySupport" - CAx Data in the Internet (<https://support.industry.siemens.com/my/ww/en/CAxOnline>).

## Application examples

The application examples support you with various tools and examples for solving your automation tasks. Solutions are shown in interplay with multiple components in the system - separated from the focus in individual products.

You can find the application examples on the Internet (<https://support.industry.siemens.com/sc/ww/en/sc/2054>).

## TIA Selection Tool

With the TIA Selection Tool, you can select, configure and order devices for Totally Integrated Automation (TIA).

This tool is the successor of the SIMATIC Selection Tool and combines the known configurators for automation technology into one tool.

With the TIA Selection Tool, you can generate a complete order list from your product selection or product configuration.

You can find the TIA Selection Tool on the Internet

(<https://w3.siemens.com/mcms/topics/en/simatic/tia-selection-tool>).

## SIMATIC Automation Tool

You can use the SIMATIC Automation Tool to run commissioning and maintenance activities simultaneously on various SIMATIC S7 stations as a bulk operation independently of the TIA Portal.

The SIMATIC Automation Tool provides a multitude of functions:

- Scanning of a PROFINET/Ethernet network and identification of all connected CPUs
- Address assignment (IP, subnet, gateway) and station name (PROFINET device) to a CPU
- Transfer of the data and the programming device/PC time converted to UTC time to the module
- Program download to CPU
- Operating mode switchover RUN/STOP
- Localization of the CPU by means of LED flashing
- Reading out CPU error information
- Reading the CPU diagnostic buffer
- Reset to factory settings
- Updating the firmware of the CPU and connected modules

You can find the SIMATIC Automation Tool on the Internet

(<https://support.industry.siemens.com/cs/ww/en/view/98161300>).

## PRONETA

With SIEMENS PRONETA (PROFINET network analysis), you analyze the plant network during commissioning. PRONETA features two core functions:

- The topology overview independently scans PROFINET and all connected components.
- The IO check is a fast test of the wiring and the module configuration of a system.

You can find SIEMENS PRONETA on the Internet

(<https://support.industry.siemens.com/cs/ww/en/view/67460624>).

## SINETPLAN

SINETPLAN, the Siemens Network Planner, supports you in planning automation systems and networks based on PROFINET. The tool facilitates professional and predictive dimensioning of your PROFINET installation as early as in the planning stage. In addition, SINETPLAN supports you during network optimization and helps you to exploit network resources optimally and to plan reserves. This helps to prevent problems in commissioning or failures during productive operation even in advance of a planned operation. This increases the availability of the production plant and helps improve operational safety.

The advantages at a glance

- Network optimization thanks to port-specific calculation of the network load
- Increased production availability thanks to online scan and verification of existing systems
- Transparency before commissioning through importing and simulation of existing STEP 7 projects
- Efficiency through securing existing investments in the long term and optimal exploitation of resources

You can find SINETPLAN on the Internet (<https://www.siemens.com/sinetplan>).

## Product overview

### 2.1 Properties

#### Part number

6ES7131-6BF61-0AA0

#### View of the module

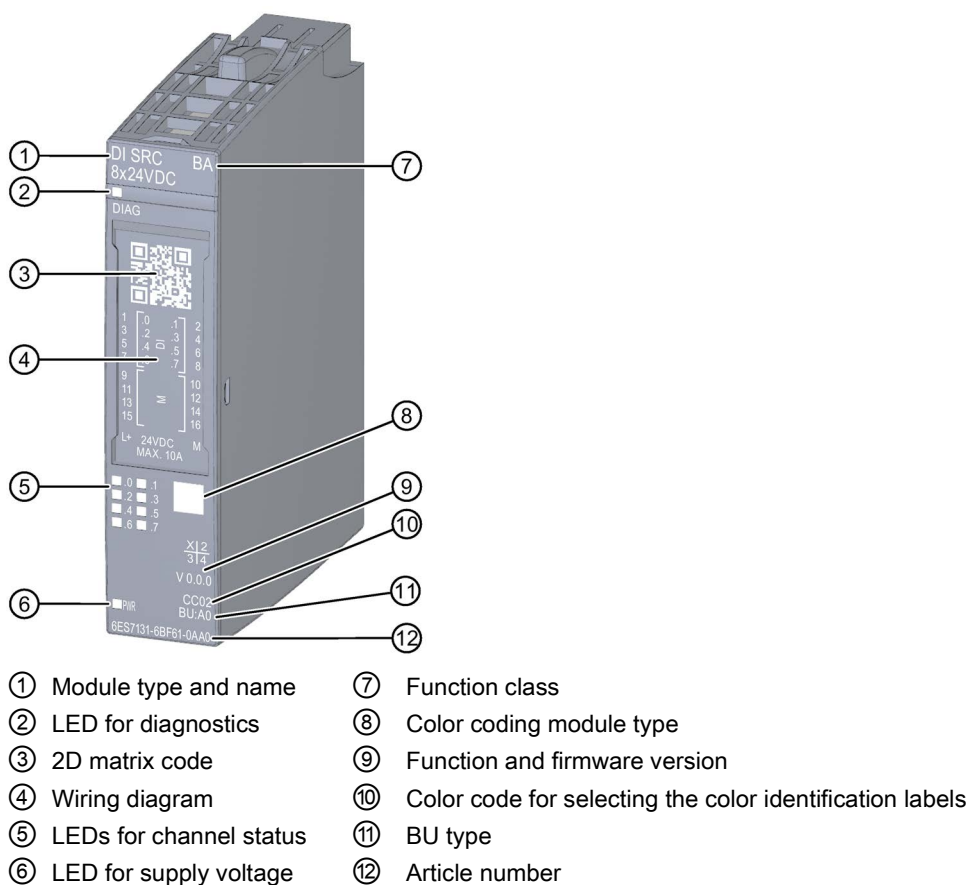

Figure 2-1 View of the DI 8×24VDC SRC BA module

## Properties

The module has the following technical properties:

- 8 digital inputs
- Source input (NPN, M reading)
- Supply voltage L+
- Configurable input delay 0.05 ms to 20 ms (per channel)
- Configurable diagnostics (per module)
- Suitable for connection of switches and 2-wire sensors according to IEC 61131, type 1 and 3

The module supports the following functions:

Table 2- 1 Version dependencies of the functions

Function	HW version	FW version	STEP 7		GSD file	
			TIA Portal	V5.x	PROFINET IO	PROFIBUS DP
Identification data I&M0 to I&M3	FS01	V0.0.0 and higher	V14 or higher with HSP 0222	V5.5 SP3 or higher with HSP 0229 V7.0	X	X
Configuration in RUN	FS01	V0.0.0 and higher	V14 or higher with HSP 0222	V5.5 SP3 or higher with HSP 0229 V7.0	X	X

## Accessories

The following accessories are supplied with the module and can also be ordered separately as spare parts:

- Labeling strips
- Color identification labels
- Reference identification label
- Shield connector

## See also

You can find additional information on the accessories in the ET 200SP distributed I/O system (<http://support.automation.siemens.com/WW/view/en/58649293>) system manual.

## 3.1 Wiring and block diagram

This section includes the block diagram of the DI 8x24VDC SRC BA module with the terminal assignments for a 1-wire, 2-wire and 3-wire connection.

Information about wiring of the BaseUnit is available in the system manual ET 200SP distributed I/O system (<http://support.automation.siemens.com/WW/view/en/58649293>).

---

**Note**

You may use and combine the different wiring options for all channels.

---

**Note**

The load group of the module must begin with a light-colored BaseUnit. Keep this in mind also during the configuration.

---

**Note**

The input channels provide values even without connected supply voltage L+. The characteristic type 2 is only maintained with connected supply voltage L+.

---

**Connection: 1-wire and 2-wire connection**

The following figure shows the block diagram and an example of the terminal assignment of the digital input module DI 8x24VDC SRC BA on the BaseUnit BU type A0 without AUX terminals (1-wire and 2-wire connection).

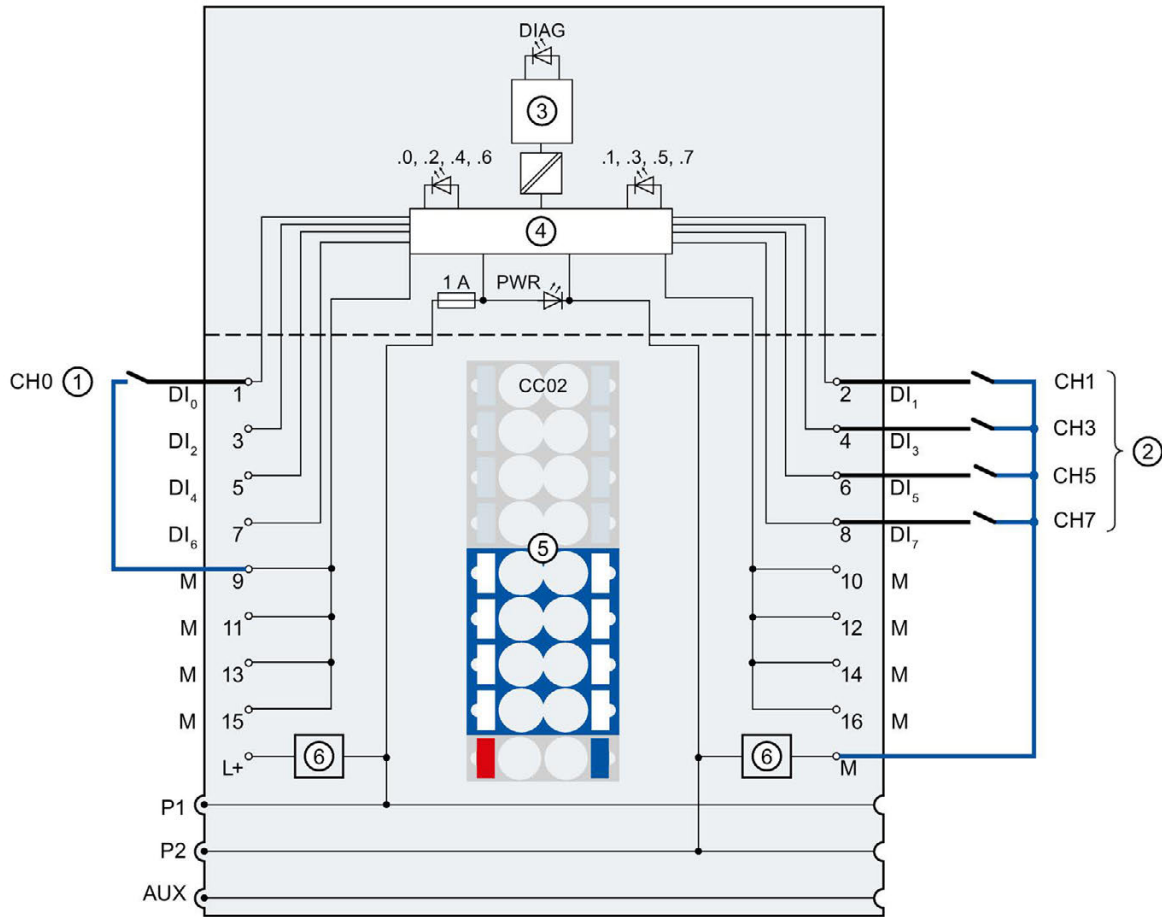

①	1-wire connection	DI <sub>n</sub>	Input signal, channel n
②	2-wire connection	24 V DC	Encoder supply, channel n
③	Backplane bus interface	L+	24 V DC (feed for light-colored BaseUnit only)
④	Input electronics	M	Ground
⑤	Color identification label CCxx (optional)	DIAG	Error or Diagnostics LED (green, red)
⑥	Filter connection supply voltage (only when light-colored BaseUnit is present)	.0 to .7	Channel status LED (green)
P1, P2, AUX	Internal self-assembling voltage buses Connection to left (dark-colored BaseUnit) Connection to left interrupted (light-colored BaseUnit)	PWR	Power LED (green)

Figure 3-1 Wiring and block diagram for 1-wire and 2-wire connection of encoders

**Connection: 3-wire connection**

The following figure shows the block diagram and an example of the terminal assignment of the digital input DI 8x24VDC SRC BA on the BaseUnit BU type A0 with AUX terminals (3-wire connection).

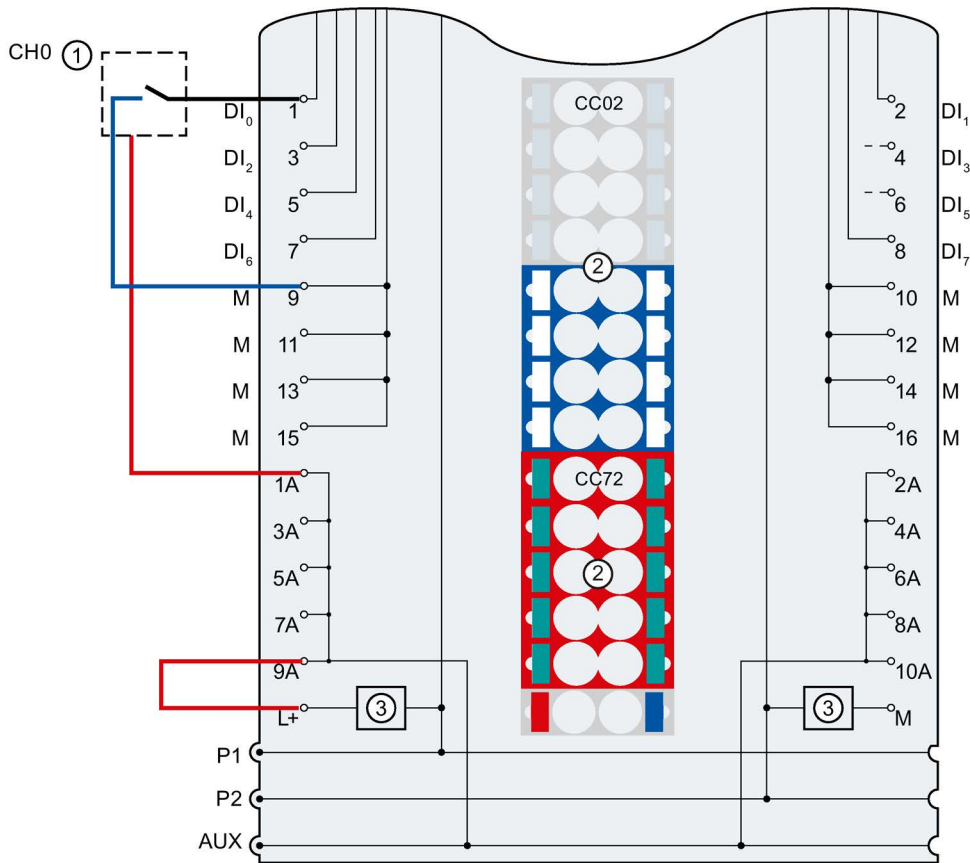

- ① 3-wire connection
- ② Color identification labels CCxx (optional)
- ③ Filter connection supply voltage (only when light-colored BaseUnit is present)
- DI<sub>n</sub> Input signal, channel n
- 24 V DC Encoder supply, channel n
- L+ 24 V DC (feed for light-colored BaseUnit only)
- M Ground
- 1 A to 10 A AUX terminals
- P1, P2, AUX Internal self-assembling voltage buses
- Connection to left (dark-colored BaseUnit)
- Connection to left interrupted (light-colored BaseUnit)

Figure 3-2 Wiring and block diagram for 3-wire connection of encoders

## Parameters/address space

### 4.1 Parameters

#### DI 8x24VDC SRC BA parameters

Specify the module properties with the various parameters in the course of your STEP 7 configuration. The following table lists the configurable parameters. The effective range of the configurable parameters depends on the type of configuration.

The following configurations are possible:

- Central operation with an ET 200SP CPU
- Distributed operation on PROFINET IO in an ET 200SP system
- Distributed operation with PROFIBUS DP in an ET 200SP system

When assigning parameters in the user program, use the "WRREC" instruction to transfer the parameters to the module by means of data records (see chapter Parameter assignment and structure of the parameter data record (Page 26)).

Table 4- 1 Configurable parameters and their defaults (GSD file)

Parameter	Value range	Default	Reconfigu- ration in RUN	Scope with configuration soft- ware, e.g. STEP 7 (TIA Portal)	
				GSD file PROFINET IO	GSD file PROFIBUS DP
Diagnostics No supply voltage L+	<ul style="list-style-type: none"> <li>• Disable</li> <li>• Enable</li> </ul>	Disable	Yes	Module	Module
Channel activated	<ul style="list-style-type: none"> <li>• Disable</li> <li>• Enable</li> </ul>	Enable	Yes	Channel	Channel

4.1 Parameters

Parameter	Value range	Default	Reconfiguration in RUN	Scope with configuration software, e.g. STEP 7 (TIA Portal)	
				GSD file PROFINET IO	GSD file PROFIBUS DP
Input delay	<ul style="list-style-type: none"> <li>• None</li> <li>• 0.05 ms</li> <li>• 0.1 ms</li> <li>• 0.4 ms</li> <li>• 0.8 ms</li> <li>• 1.6 ms</li> <li>• 3.2 ms</li> <li>• 12.8 ms</li> <li>• 20 ms</li> </ul>	3.2 ms	Yes	Channel	Module <sup>1</sup>
Potential group	<ul style="list-style-type: none"> <li>• Use potential group of the left module (module plugged into a dark-colored BaseUnit)</li> <li>• Enable new potential group (module plugged into light-colored BaseUnit)</li> </ul>	Use potential group of the left module	No	Module	Module

<sup>1</sup> Due to the limited number of parameters of a maximum of 244 bytes per ET 200SP station with a PROFIBUS GSD configuration, the parameter assignment options are restricted. The parameter length of the I/O module is 3 bytes with PROFIBUS GSD configuration. If necessary, you can set this parameter by using the data record 128, see the appendix "Parameter data record".

## 4.2 Explanation of parameters

### **Diagnostics: No supply voltage L+**

Enabling of the diagnostics for no or insufficient supply voltage L+.

### **Channel activated**

Determines whether a channel is activated or deactivated.

### **Input delay**

This parameter can be used to suppress signal interference. Changes to the signal are only detected if they are constantly pending longer than the set input delay time.

### **Potential group**

A potential group consists of a group of directly adjacent I/O modules within an ET 200SP station, which are supplied via a common supply voltage.

A potential group begins with a light-colored BaseUnit through which the required voltage is supplied for all modules of the potential group. The light-colored BaseUnit interrupts the three self-assembling voltage buses P1, P2 and AUX to the left neighbor.

All additional I/O modules of this potential group are plugged into dark-colored BaseUnits. You take the potential of the self-assembling voltage buses P1, P2 and AUX from the left neighbor.

A potential group ends with the dark-colored BaseUnit, which follows a light-colored BaseUnit or server module in the station configuration.

### 4.3 Address space

The module can be configured differently in STEP 7; see following table. Depending on the configuration, additional/different addresses are assigned in the process image of the inputs.

#### Configuration options of DI 8x24VDC SRC BA

You can configure the module with STEP 7 (TIA Portal) or with a GSD file. If you configure the module using a GSD file, the configurations are available under various short designations/module names; see the table below. The following configurations are possible:

Table 4-2 Configuration options with GSD file

Configuration	Short designation/module name in the GSD file	Configuration software, e.g. with STEP 7 (TIA Portal)		
		Integrated in hardware catalog STEP 7	GSD file PROFINET IO	GSD file PROFIBUS DP
1 x 8-channel without value status	DI 8x24VDC SRC BA V0.0	V14, SP1 or higher with HSP 0222	X	X

#### Address space of the digital input module DI 8x24VDC SRC BA

The figure below shows the assignment of the address space for DI 8x24VDC SRC BA.

Assignment in the process image input (PII)

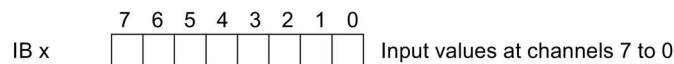

Figure 4-1 Address space of the digital input module DI 8x24VDC SRC BA

## Interrupts/diagnostics alarms

### 5.1 Status and error displays

#### LED displays

The figure below shows the LED displays (status and error displays) of the DI 8x24VDC SRC BA.

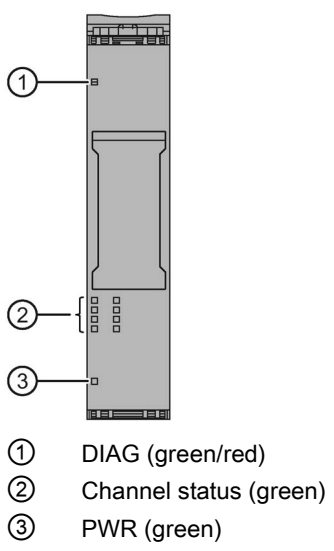





Figure 5-1 LED display

**Meaning of the LED displays**

The tables below explain the meaning of the Status and error displays. Remedial measures for diagnostics alarms can be found in section Diagnostics alarms (Page 21).



**LED DIAG**

Table 5- 1 Error display of the LED DIAG

LED DIAG	Meaning
 Off	Backplane bus supply of the ET 200SP not OK
 Flashes	Module parameters not assigned
 On	Module parameters assigned
 Flashes	Module diagnostics is available



**LED channel status**

Table 5- 2 Status display of the LED channel status

LED channel status	Meaning
 Off	Process signal = 0
 On	Process signal = 1

**LED PWR**

Table 5- 3 Status display of the LED PWR

LED PWR	Meaning
 Off	No supply voltage L+
 On	Supply voltage L+ present

## 5.2 Interrupts

The DI 8x24VDC SRC BA digital input module supports diagnostics interrupts.

### Diagnostics interrupts

The module generates a diagnostic interrupt at the following event:

- Parameter assignment error
- No supply voltage

Detailed information on the event is available in the STEP 7 online help.

## 5.3 Diagnostics alarms

### Diagnostics alarms

A diagnostic alarm is generated and the DIAG-LED flashes on the module for each diagnostics event. You can read out the diagnostics alarms, for example, in the diagnostics buffer of the CPU. You can evaluate the error codes with the user program.

Table 5- 4 Diagnostics alarms, their meaning and corrective measures

Diagnostics alarm	Error code	Meaning	Remedy
Parameter assignment error	10 <sub>H</sub>	<ul style="list-style-type: none"> <li>• The module cannot evaluate parameters for the channel.</li> <li>• Incorrect parameter assignment.</li> </ul>	Correct the parameter assignment
No supply voltage	11 <sub>H</sub>	No or insufficient supply voltage L+	<ul style="list-style-type: none"> <li>• Check supply voltage L+ on the BaseUnit</li> <li>• Check BaseUnit type</li> </ul>

# Technical specifications

## 6.1 Technical specifications

### Technical specifications of DI 8x24VDC SRC BA

The following table shows the technical specifications as of 02/2019. You will find a data sheet including daily updated technical specifications on the Internet (<https://support.industry.siemens.com/cs/ww/en/pv/6ES7131-6BF61-0AA0/td?dl=en>).

Article number	6ES7131-6BF61-0AA0
<b>General information</b>	
Product type designation	DI 8x24 VDC SRC BA
HW functional status	From FS02
Firmware version	V0.0
<ul style="list-style-type: none"> <li>FW update possible</li> </ul>	No
usable BaseUnits	BU type A0
Color code for module-specific color identification plate	CC02
<b>Product function</b>	
<ul style="list-style-type: none"> <li>I&amp;M data</li> </ul>	Yes; I&M0 to I&M3
<b>Engineering with</b>	
<ul style="list-style-type: none"> <li>STEP 7 TIA Portal configurable/integrated as of version</li> </ul>	V14
<ul style="list-style-type: none"> <li>STEP 7 configurable/integrated as of version</li> </ul>	V5.5 SP3 / -
<ul style="list-style-type: none"> <li>PROFIBUS as of GSD version/GSD revision</li> </ul>	One GSD file each, Revision 3 and 5 and higher
<ul style="list-style-type: none"> <li>PROFINET as of GSD version/GSD revision</li> </ul>	GSDML V2.3
<b>Operating mode</b>	
<ul style="list-style-type: none"> <li>DI</li> </ul>	Yes
<ul style="list-style-type: none"> <li>Counter</li> </ul>	No
<ul style="list-style-type: none"> <li>Oversampling</li> </ul>	No
<ul style="list-style-type: none"> <li>MSI</li> </ul>	No
<b>Supply voltage</b>	
Rated value (DC)	24 V
permissible range, lower limit (DC)	19.2 V
permissible range, upper limit (DC)	28.8 V
Reverse polarity protection	Yes

<b>Article number</b>	<b>6ES7131-6BF61-0AA0</b>
<b>Encoder supply</b>	
Short-circuit protection	No
<b>Power loss</b>	
Power loss, typ.	1.5 W
<b>Address area</b>	
<b>Address space per module</b>	
• Inputs	1 byte
<b>Hardware configuration</b>	
Automatic encoding	Yes
<b>Selection of BaseUnit for connection variants</b>	
• 1-wire connection	BU type A0
• 2-wire connection	BU type A0
• 3-wire connection	BU type A0 with AUX terminals or potential distributor module
• 4-wire connection	BU type A0 + Potential isolation module
<b>Digital inputs</b>	
Number of digital inputs	8
Digital inputs, parameterizable	Yes
Source/sink input	m-reading
Input characteristic curve in accordance with IEC 61131, type 1	Yes
<b>Input voltage</b>	
• Rated value (DC)	24 V
• for signal "0"	30 V to -5 V (reference potential is L+)
• for signal "1"	-11 V to -30 V (reference potential is L+)
<b>Input current</b>	
• for signal "1", typ.	6 mA
<b>Input delay (for rated value of input voltage) for standard inputs</b>	
– parameterizable	Yes; 0.05 / 0.1 / 0.4 / 0.8 / 1.6 / 3.2 / 12.8 / 20 ms (in each case + delay of 30 to 500 µs, depending on line length)
– at "0" to "1", min.	0.05 ms
– at "0" to "1", max.	20 ms
– at "1" to "0", min.	0.05 ms
– at "1" to "0", max.	20 ms
<b>Cable length</b>	
• shielded, max.	1 000 m
• unshielded, max.	200 m

6.1 Technical specifications

<b>Article number</b>	<b>6ES7131-6BF61-0AA0</b>
<b>Encoder</b>	
<b>Connectable encoders</b>	
<ul style="list-style-type: none"> <li>• 2-wire sensor</li> </ul>	Yes
<ul style="list-style-type: none"> <li>– permissible quiescent current (2-wire sensor), max.</li> </ul>	1.5 mA
<b>Isochronous mode</b>	
Isochronous operation (application synchronized up to terminal)	No
<b>Interrupts/diagnostics/status information</b>	
Diagnostics function	Yes
<b>Alarms</b>	
<ul style="list-style-type: none"> <li>• Diagnostic alarm</li> </ul>	Yes
<b>Diagnostic messages</b>	
<ul style="list-style-type: none"> <li>• Diagnostic information readable</li> </ul>	Yes
<ul style="list-style-type: none"> <li>• Monitoring the supply voltage</li> </ul>	Yes
<ul style="list-style-type: none"> <li>– parameterizable</li> </ul>	Yes
<ul style="list-style-type: none"> <li>• Monitoring of encoder power supply</li> </ul>	No
<ul style="list-style-type: none"> <li>• Wire-break</li> </ul>	No
<ul style="list-style-type: none"> <li>• Short-circuit</li> </ul>	No
<b>Diagnostics indication LED</b>	
<ul style="list-style-type: none"> <li>• Monitoring of the supply voltage (PWR-LED)</li> </ul>	Yes; green PWR LED
<ul style="list-style-type: none"> <li>• Channel status display</li> </ul>	Yes; Green LED
<ul style="list-style-type: none"> <li>• for channel diagnostics</li> </ul>	No
<ul style="list-style-type: none"> <li>• for module diagnostics</li> </ul>	Yes; green/red DIAG LED
<b>Potential separation</b>	
<b>Potential separation channels</b>	
<ul style="list-style-type: none"> <li>• between the channels</li> </ul>	No
<ul style="list-style-type: none"> <li>• between the channels and backplane bus</li> </ul>	Yes
<ul style="list-style-type: none"> <li>• between the channels and the power supply of the electronics</li> </ul>	No
<b>Isolation</b>	
Isolation tested with	707 V DC (type test)
<b>Standards, approvals, certificates</b>	
Suitable for safety functions	No

<b>Article number</b>	<b>6ES7131-6BF61-0AA0</b>
<b>Ambient conditions</b>	
<b>Ambient temperature during operation</b>	
• horizontal installation, min.	-30 °C
• horizontal installation, max.	60 °C
• vertical installation, min.	-30 °C
• vertical installation, max.	50 °C
<b>Altitude during operation relating to sea level</b>	
• Installation altitude above sea level, max.	2 000 m; On request: Installation altitudes greater than 2 000 m
<b>Dimensions</b>	
Width	15 mm
Height	73 mm
Depth	58 mm
<b>Weights</b>	
Weight, approx.	28 g

### Dimensional drawing

See the manual ET 200SP BaseUnits  
(<http://support.automation.siemens.com/WW/view/en/58532597/133300>)

## Parameter data record

### A.1 Parameter assignment and structure of parameter data record

The data record of the module has an identical structure, regardless of whether you configure the module with PROFIBUS DP or PROFINET IO. With data record 128, you can reconfigure the module in your user program regardless of your programming. This means that you can use all the functions of the module even if you configured it via PROFIBUS-GSD.

#### Parameter assignment in the user program

The module parameters can be re-assigned in RUN (for example, the input delay of selected channels can be edited in RUN without having an effect on the other channels).

#### Changing parameters in RUN

The "WRREC" instruction is used to transfer the parameters to the module using data record 128. The parameters set in STEP 7 are not changed in the CPU, which means the parameters set in STEP 7 will be valid again after a restart.

#### Output parameter STATUS

The module ignores errors that occur during the transfer of parameters with the "WRREC" instruction and continues operation with the previous parameter assignment. However, a corresponding error code is written to the STATUS output parameter.

The description of the "WRREC" instruction and the error codes is available in the STEP 7 online help.

Structure of data record 128

**Note**

Channel 0 includes the diagnostics for the entire module.

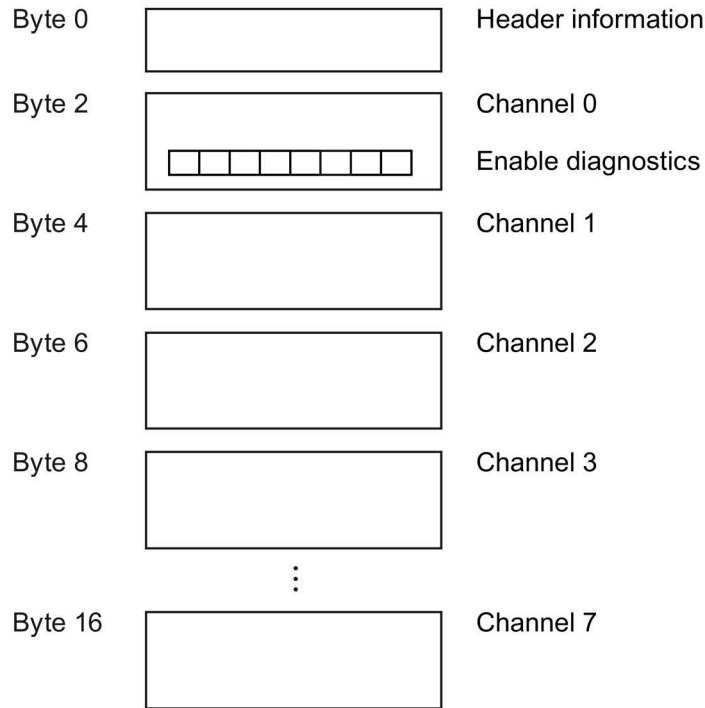

Figure A-1 Structure of data record 128

**Header information**

The figure below shows the structure of the header information.

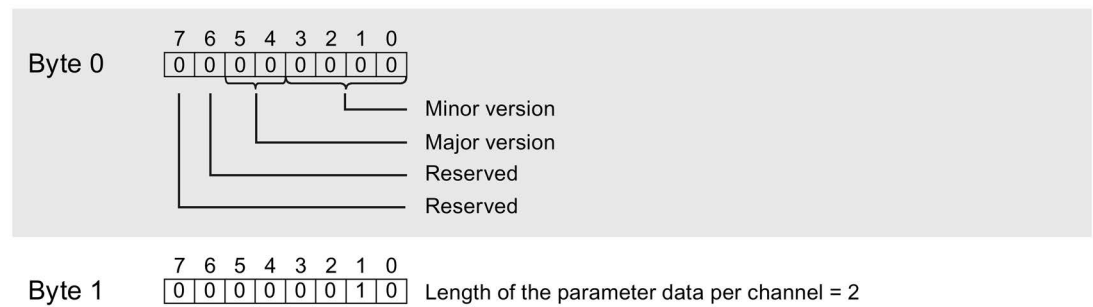
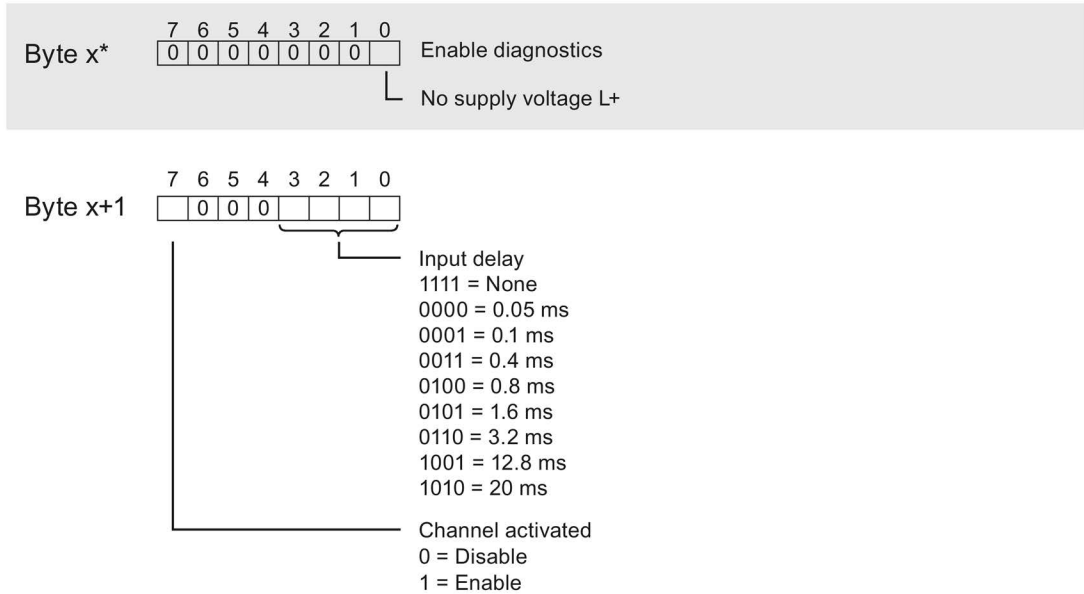

Figure A-2 Header information

### Parameters

The figure below shows the structure of the parameters for channels 0 to 7.  
Enable a parameter by setting the corresponding bit to "1".



\*  $x = 2 + (\text{channel number} \times 2)$ ; channel number = 0 to 7

Figure A-3 Structure byte x to x+1 for the channels 0 to 7

## Error transferring the data record

The module always checks all the values of the transferred data record. Only if all the values were transferred without errors does the module apply the values from the data record.

The WRREC instruction for writing data records returns corresponding error codes when errors occur in the STATUS parameter, see also the description of the "STATUS" parameter in the STEP 7 online help).

The following table shows the module-specific error codes and their meaning for the parameter data record 128.

Error code in STATUS parameter (hexadecimal)				Meaning	Solution
Byte 0	Byte 1	Byte 2	Byte 3		
DF	80	B0	xx	Number of the data record unknown.	Enter a valid number for the data record.
DF	80	B1	xx	Length of the data record incorrect.	Enter a valid value for the data record length.
DF	80	B2	xx	Slot invalid or cannot be accessed.	<ul style="list-style-type: none"> <li>Check the station whether the module is plugged or drawn.</li> <li>Check the assigned values for the parameters of the WRREC instruction.</li> </ul>
DF	80	E0	xx	Wrong version or error in the header information.	Correct the version, length and number of parameter blocks.
DF	80	E1	07	Invalid coding for input filter time.	Check the parameters of the module.